



ASSEMBLY & INSTALLATION GUIDE

PK-4-1





PRIOR TO INSTALLATION:

PLEASE CAREFULLY READ AND ADHERE TO ALL WARNINGS AND INSTALLATION GUIDELINES BEFORE USING THIS PRODUCT. FAILURE TO DO SO MAY RESULT IN PROPERTY DAMAGE, SEVERE BODILY INJURY, AND/OR LOSS OF LIFE. THE MANUFACTURER DISCLAIMS ANY RESPONSIBILITY FOR PROPERTY DAMAGE, PERSONAL INJURY, OR FATALITIES THAT MAY OCCUR WHILE UTILIZING PACKD PRODUCTS.

- Neglecting to utilize the provided fasteners, brackets, and following proper installation guidelines may heighten the risk of severe personal injury and/or fatality.
- In instances where drilling is necessary for installation, improper drilling may lead to vehicle damage, electric shock, fire, or fatality.
- If drilling is necessary, ensure that it is restricted to areas authorized by the vehicle's Original Equipment Manufacturer's Body Builders Layout Book (or equivalent document).
- Prior to drilling, verify that critical vehicle components such as the gas tank, wiring harness, or hoses will not be impacted. Consult the vehicle OEM documentation as needed and use a drill collar during drilling to minimize the risk of vehicle damage.
- Before installation, inspect the vehicle to guarantee that the installation will not obstruct critical components such as electrical wiring, fuel tanks, fuel cells, locks, latches, etc.
- The installer or upfitter is responsible for ensuring that anchorages are securely installed on appropriate wall and floor structures.
- Avoid installing systems into weak or unsound materials such as plastics, woods, thin-walled metals, etc., without proper reinforcement.
- Do not install this product in a manner that could interfere with airbag deployment.
- Incorrect installation may lead to water leaks, electric shock, or fire.
- Secure all items in the cargo area properly, and close partition doors while the vehicle is in motion.
- Any modification or unintended use of this product could create a hazardous condition and void the warranty.
- Opt for professional installation conducted by certified technicians well-versed in vehicle upfitting procedures. Entrusting the installation to amateurs could jeopardize both the effectiveness and safety of the product.
- Adhere to local, state, and federal regulations governing vehicle modifications. Failure to comply with these regulations may result in serious legal consequences.

Contents

ASSEMBLY INSTRUCTIONS	4
1 PREPARATION	4
2 INSTALLATION FASTENER KIT.....	5
3 PARTSKEEPER ASSEMBLY	6
INSTALLATION INSTRUCTONS.....	7
1 FASTENING BRACKETS TO END PANELS.....	7
2 MARKING HOLES FOR PLUS NUTS	8
3 INSTALLING PLUS NUTS	9
4 FASTENING PARTSKEEPER UNIT TO THE WALL.....	11
5 FASTENING PARTSKEEPER UNIT TO SHELF UNIT	13
6 FASTENING PARTSKEEPER UNIT TO THE FLOOR.....	14

Required Items

- 2 People (To Lift Partskeeper Unit)
- Rivet Gun
- 3/8" Drill Bit
- 3/8" Nut Driver Bit
- 1/2" Drill Bit w/ Drill Collar (Set at 1/2")
- 1/2" Nut Driver Bit
- 9/16" Wrench
- 1" Hole Saw
- Plus Nut Tool or Plus Nut Gun (5/16")
- Marker
- Cordless Drill
- Cordless Impact Driver
- Tape Measure
- Large Square

ASSEMBLY INSTRUCTIONS

1 PREPARATION



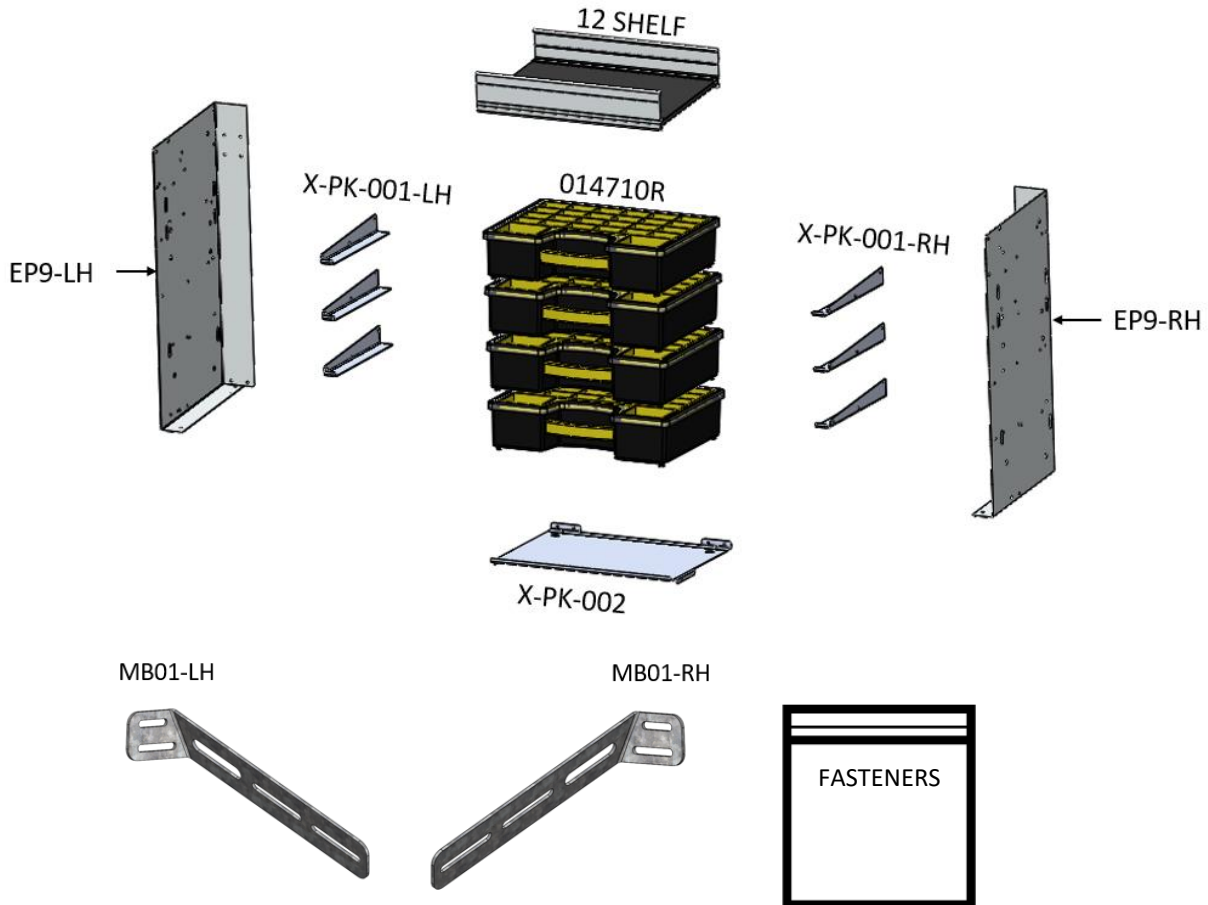





Unpack components and compare to the Bill of Materials. Ensure that all of the parts are present.

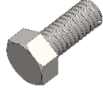

BILL OF MATERIALS

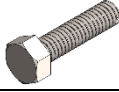
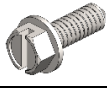
Part Number	Description	Quantity
EP9-LH	SFO Aluminum LH Partskeeper/Tank Holder 45"	1
EP9-RH	SFO Aluminum RH Partskeeper/Tank Holder 45"	1
12" Shelf	Shelf Tray Assembly, 12"	1
014710R	Stanley Parts Organizer, 4.5" deep, 10 Compartments	4
X-PK-001-LH	Partskeeper Track Stanley LH	3
X-PK-001-RH	Partskeeper Track Stanley RH	3
X-PK-002	Partskeeper Base Stanley	1
MB01-LH	Shelf Mounting Bracket, LH	1
MB01-RH	Shelf Mounting Bracket, RH	1
HK06	Hardware Kit	1

2 INSTALLATION FASTENER KIT

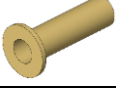
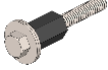
Quantity	Description	Image	QC
8	Hex Washer Head Screw #14 x 1"		
8	Steel Blind Rivet 3/16" x 1/2" LG		
4	Hex Bolt 5/16-18 x 3/4		
4	Flat Washer 5/16		
4	Serrated Nut 5/16-18		
4	Hex Bolt 5/16-18 x 1-1/4		
4	Hex Washer Head Screw #14 x 3/4"		
4	Lock Washer 5/16		
4	Flat Washer 5/16		
4	1/4" Nylon Spacer		
4	Serrated Nut 5/16-18		
4	Plus Nut 5/16		
1	5/16" Plus Nut Tool		

3 PARTSKEEPER ASSEMBLY

1. Unmask the protective film from all surfaces of each part.
2. Rivet the Baseplate to the LH End Panel
3. Rivet the Baseplate to the RH End Panel.
4. Fasten the Shelf Tray Assembly to the End Panels.

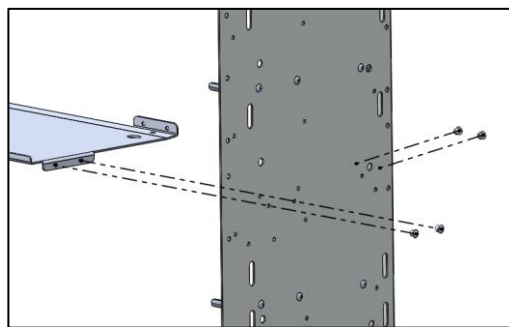
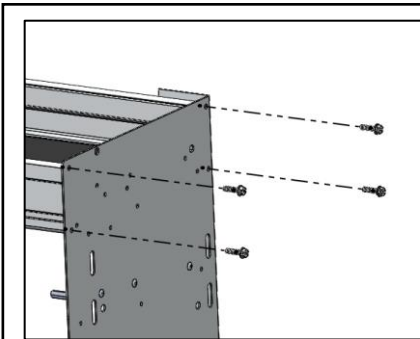
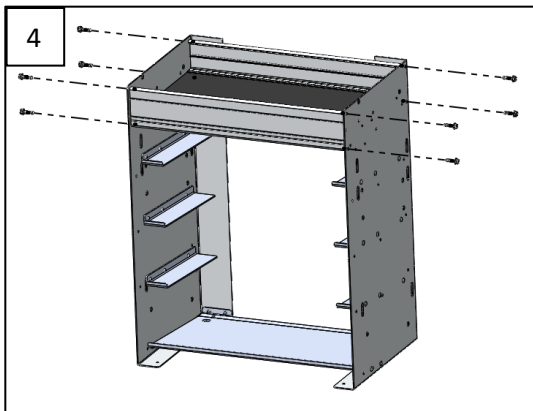
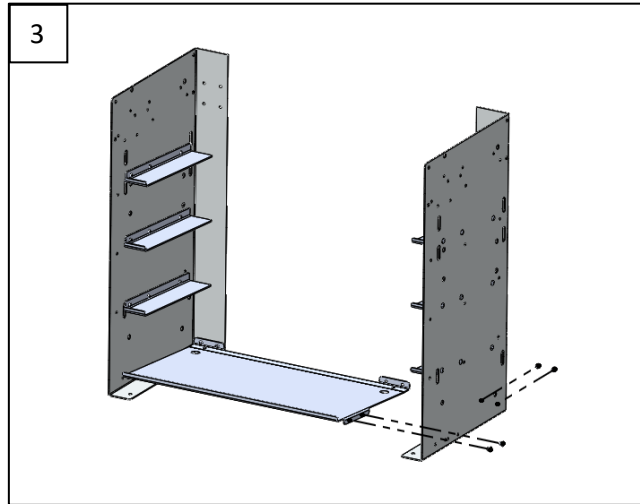
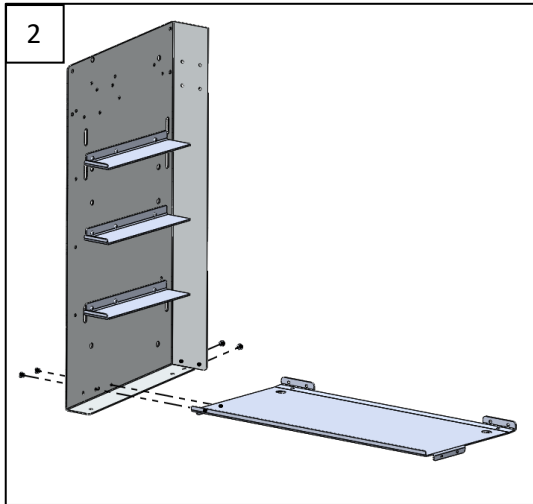

Tools Used:

- Cordless Impact Driver
- 3/8" Nut Driver Bit
- Rivet Gun

Hardware Used:

- 8 x Hex Washer Head Screw #14 X 1"
- 8 x Pop Rivet 3/16" x 0.5"LG

INSTALLATION INSTRUCTIONS

1 FASTENING BRACKETS TO END PANELS

1. Lift assembled Partskeeper Unit into vehicle and place it in the desired location.
2. Place the mounting brackets so that they align with the horizontal rim of the vehicle as shown.
3. Make 2 marks in the slots of the mounting bracket onto the end panel of the Partskeeper Unit.
4. Use a 3/8" drill bit to drill out the holes for mounting the mounting brackets onto the end panels.
5. Fasten the mounting brackets onto the end panels.

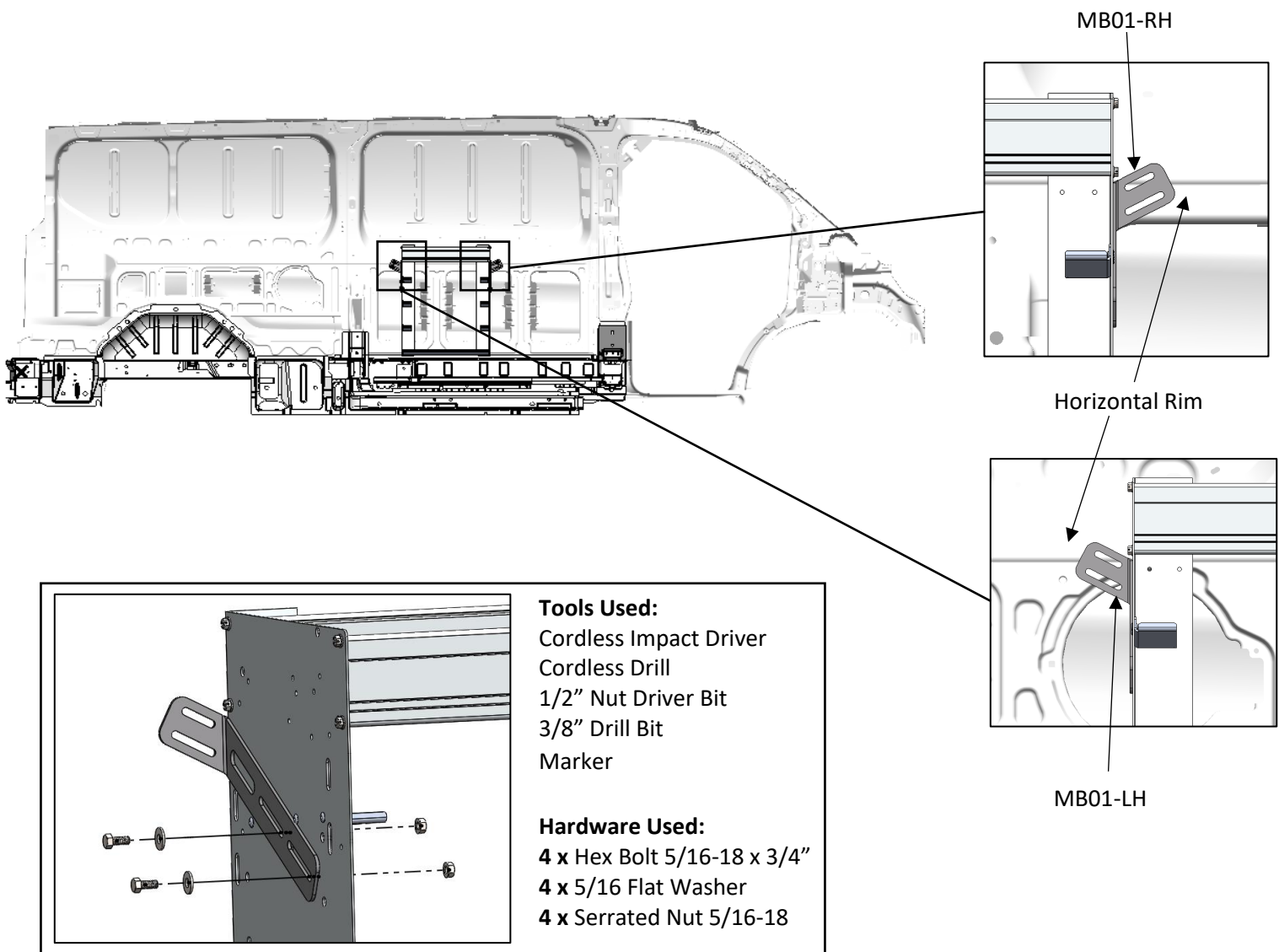

2 MARKING HOLES FOR PLUS NUTS

Mark Plus Nut Locations

Once the mounting brackets are secured to the end panels, marks can be made for installing Plus Nuts onto the vehicle. (See page 12 for vehicles with Wall Kits)

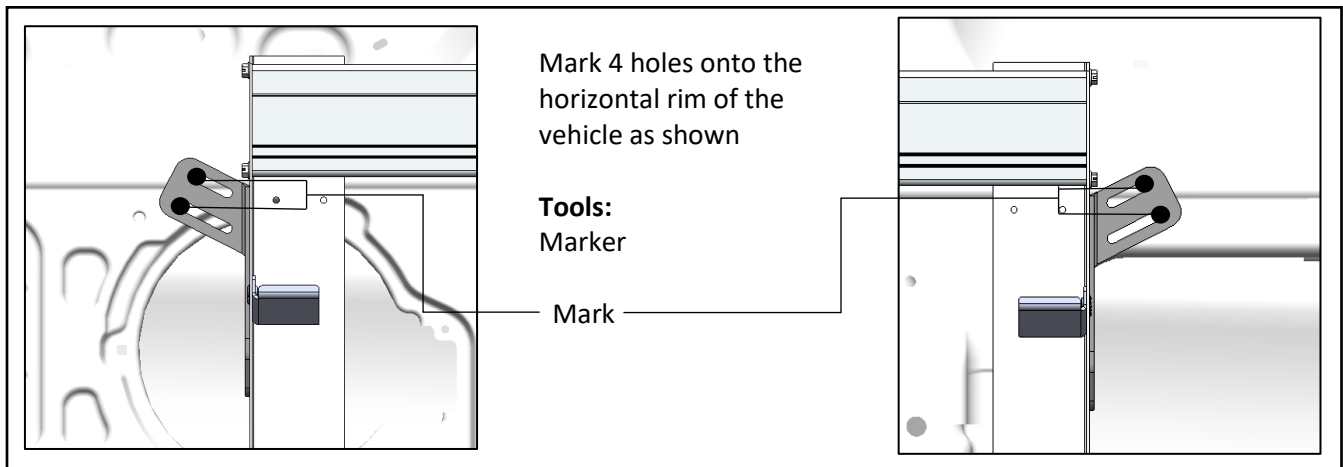
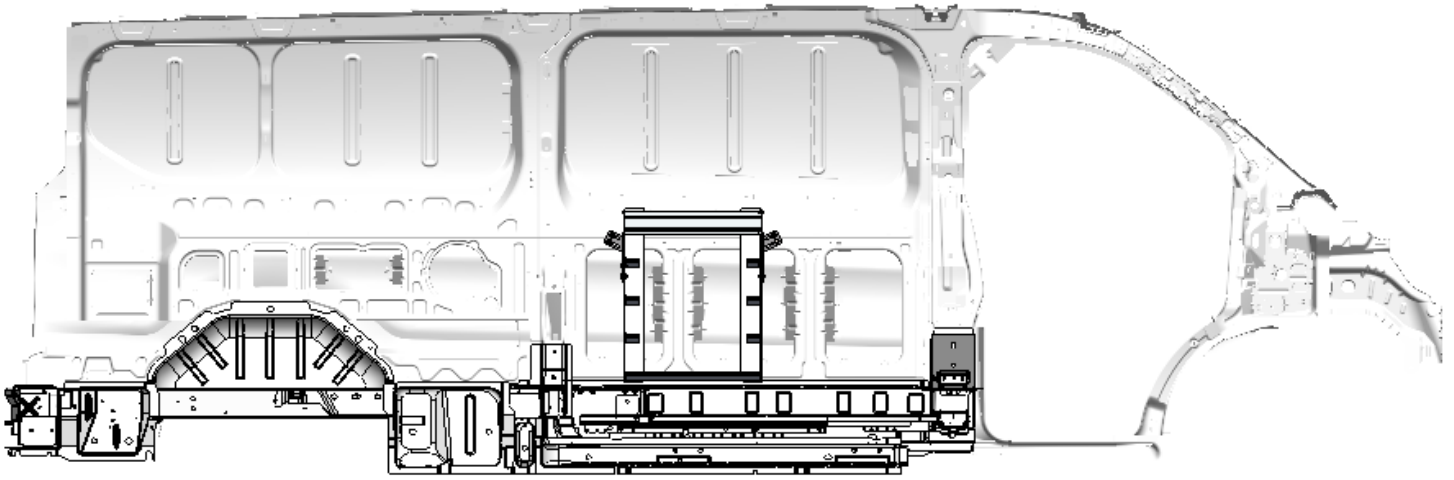

3 INSTALLING PLUS NUTS

1. Lift Partskeeper Unit so that it is out of the way.
2. Drill holes using a 1/2" drill bit with a collar to stop drill at 1/2" depth.



WARNING: Check for wiring or gas tanks BEFORE drilling into floors, pillars, headliners, or walls.

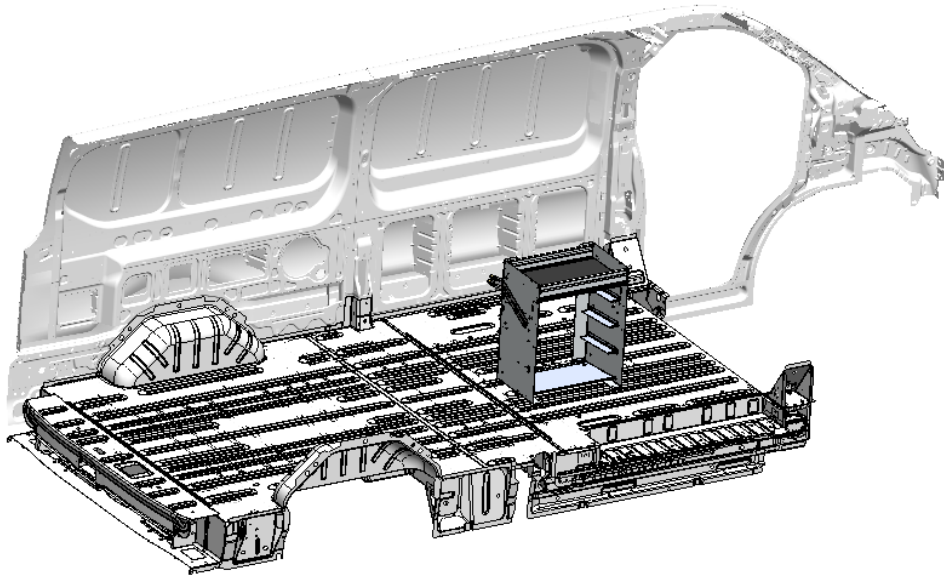

Using a 1/2" drill bit with a 1/2" Drill Collar, drill out all of the marks from the previous step. Install Plus Nuts into drilled holes. Only use Plus Nuts in places where Bolts and Nuts cannot be used.

Tools:

Cordless Drill
1/2" Drill Bit with Drill Collar (Set to 1/2" Depth)

Hardware:

4 x 5/16" Plus Nuts

Plus Nuts

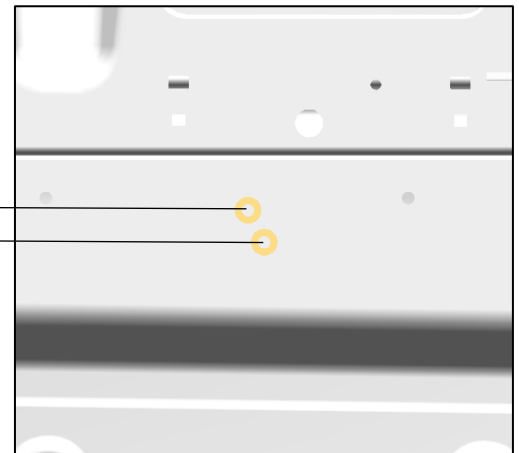

(A) Using Plus Nut Gun: (If available- otherwise see B below)

- Place 2 drops of air tool oil into the air fitting regularly.
- Ensure that there is anti-seize on the Plus Nut Gun threads at all times.
- Thread a Plus Nut onto the threads of the gun, then place bolt and Plus Nut through pre-drilled hole.
- Pull trigger of Plus Nut Gun to compress Plus Nut into the material until the noise changes on the gun.
- Reverse direction on gun to unscrew Bolt from the Plus Nut.

FORWARD

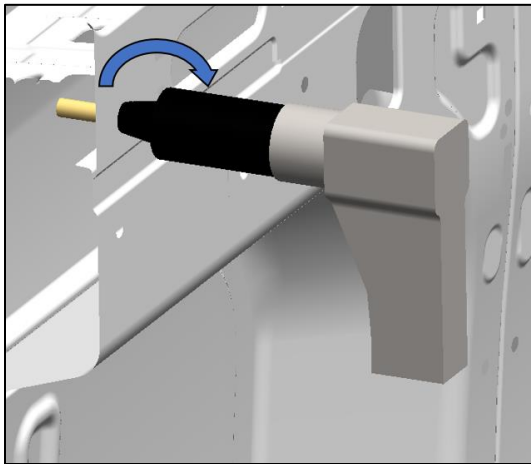

REVERSE

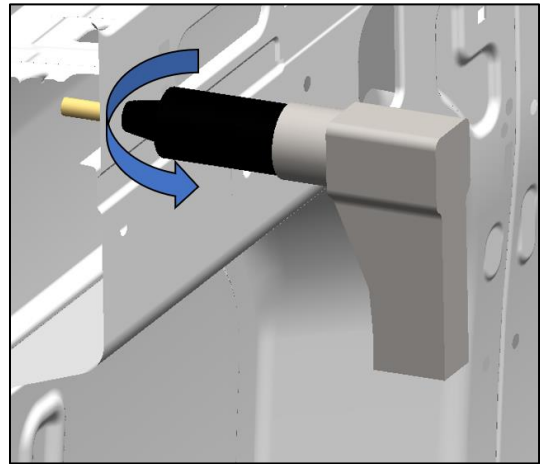

(B) Using Plus Nut Tool:

STEP 1

Assemble the Plus Nut Tool as shown.

Tools:

9/16" Wrench

Hardware:

Plus Nut Tool

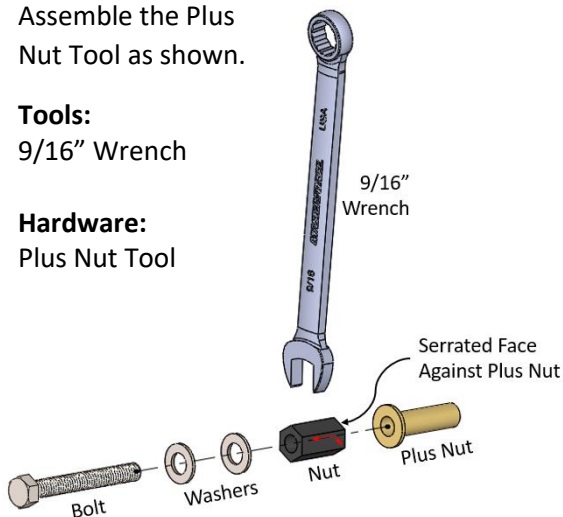

STEP 2

Fasten Plus Nut to vehicle:

- Insert Plus Nut into hole.
- Hold Nut with wrench.
- Tighten bolt until Plus Nut clamps the vehicle body metal tightly.

Tools:

Cordless Impact Driver
1/2" Nut Driver Bit
9/16" Wrench



Hardware:

4 x 5/16" Plus Nuts
Plus Nut Tool

4 FASTENING PARTSKEEPER UNIT TO THE WALL

Without Wall Kit

Lift the assembled Partskeeper Unit back into place ensuring that the slots in the mounting brackets line up with the Plus Nuts in the wall.

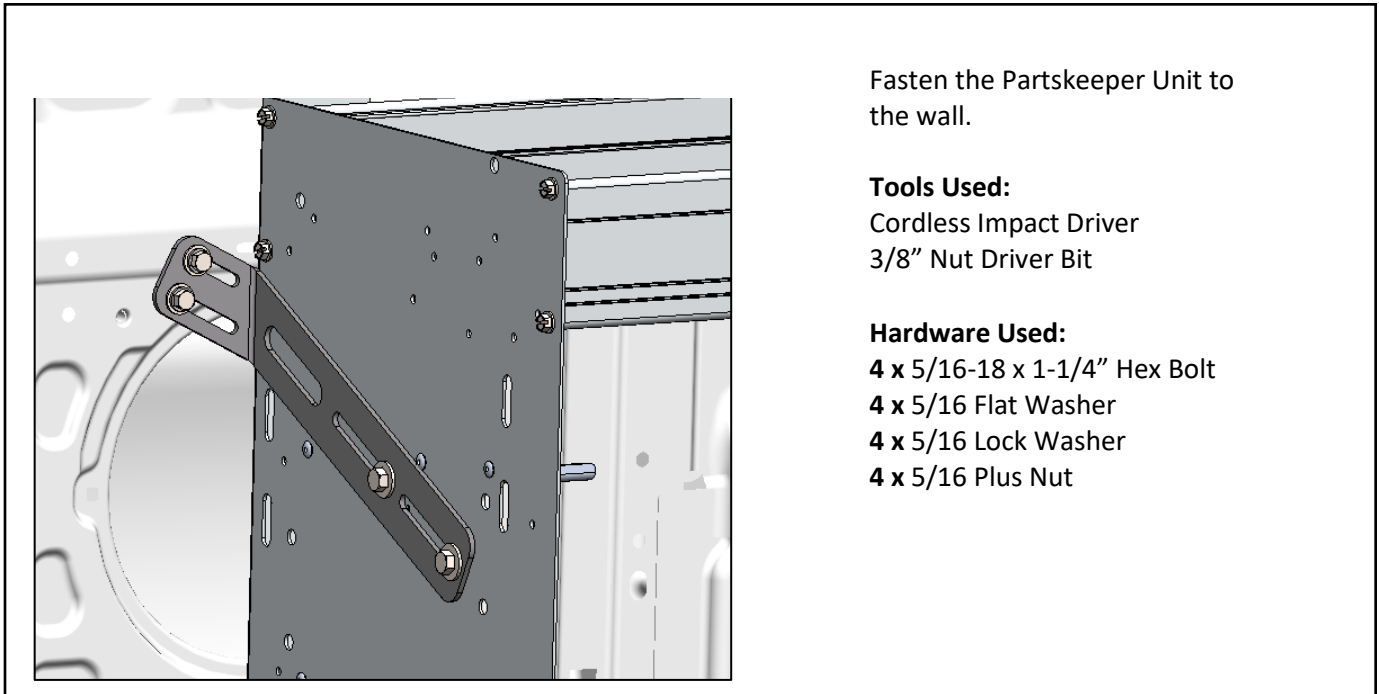
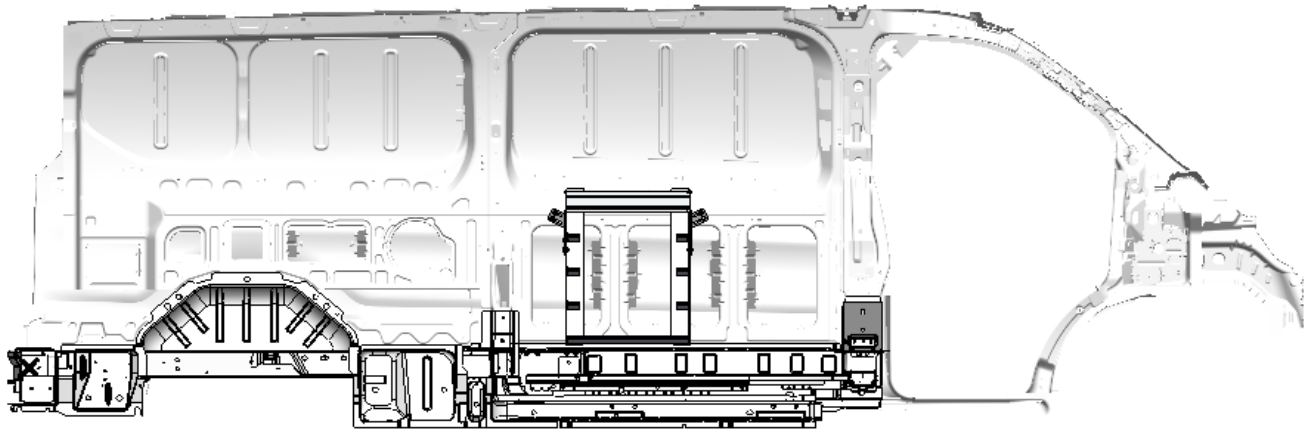

With Wall Kit

1. Make 4 marks using the slots of the mounting brackets onto the wall kit.
2. Use a 1" hole saw to carefully cut out holes in the wall kit at the desired fastener location (in the locations where plus nuts were installed).
3. Use a 1/2" drill with a collar set to a 1/2" depth to drill out the holes.
4. Install the Plus Nuts into the holes. (See page 10)
5. Fasten the Partskeeper Unit to the vehicle.

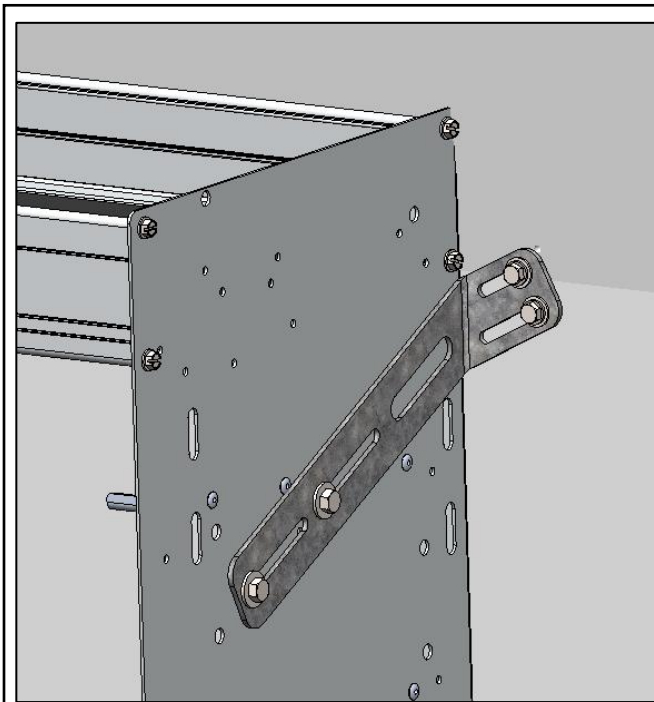
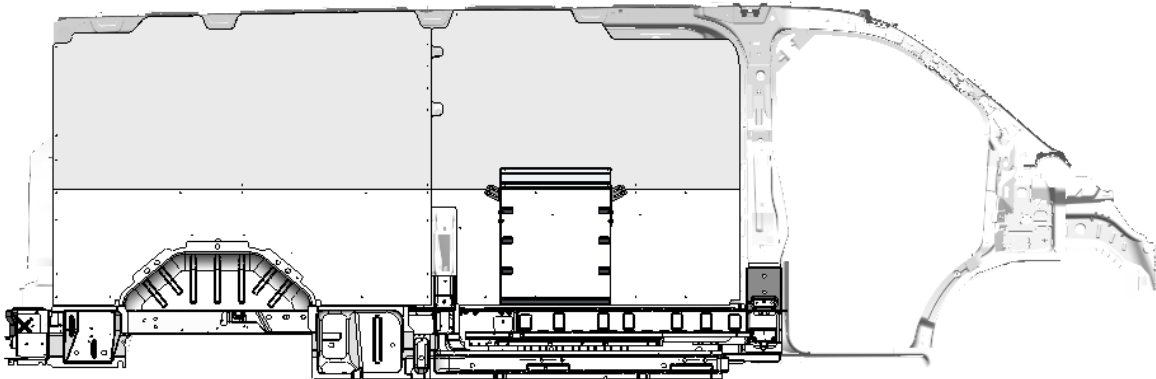

Fasten the Partskeeper Unit to the wall.

Tools Used:

Cordless Impact Driver
Cordless Drill
1" Hole Saw
1/2" Drill Bit with Drill Collar (Set to 1/2" Depth)
1/2" Nut Driver Bit

Hardware Used:

4 x 5/16-18 x 1-1/4" Hex Bolt
4 x 5/16 Flat Washer
4 x 5/16 Lock Washer
4 x 5/16 Plus Nut

5 FASTENING PARTSKEEPER UNIT TO SHELF UNIT

In many instances, Partskeeper units will be installed next to Shelf Units. In this case, one side of the Partskeeper can be bolted to the Shelf Unit. See Shelf Unit Assembly and Installation guide for instructions on how to install Shelf Unit.

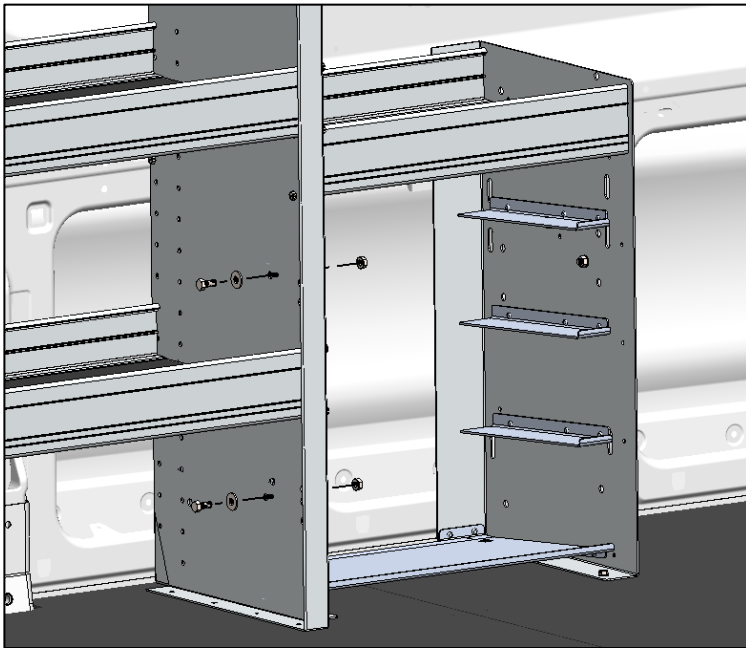
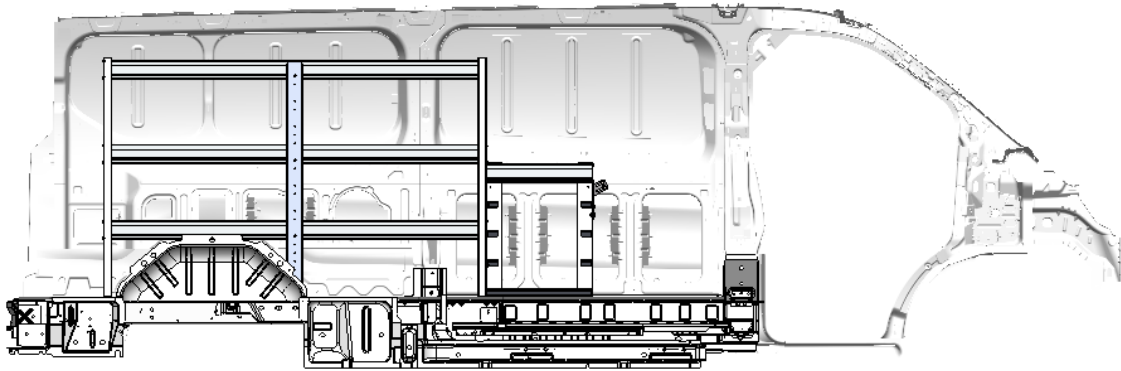

- Drill 2 holes through the Shelf Unit and Partskeeper Unit.
- Fasten the Shelf Unit to the Partskeeper Unit.

Tools Used:

Cordless Impact Driver
Cordless Drill
3/8" Drill Bit
1/2" Nut Driver Bit

Hardware Used:

2 x 5/16-18 x 1-1/4" Hex Bolt
2 x 5/16 Flat Washer
2 x 5/16 Plus Nut

6 FASTENING PARTSKEEPER UNIT TO THE FLOOR

With Floor Kit

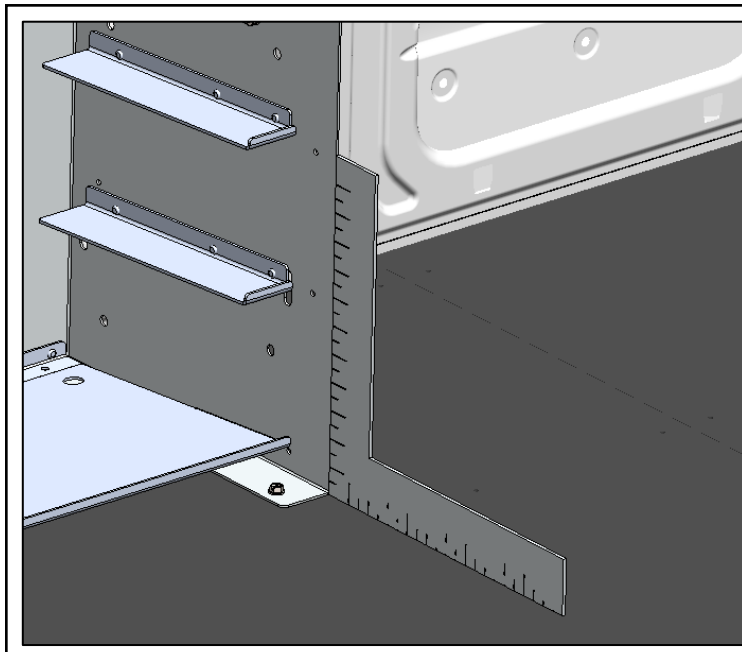
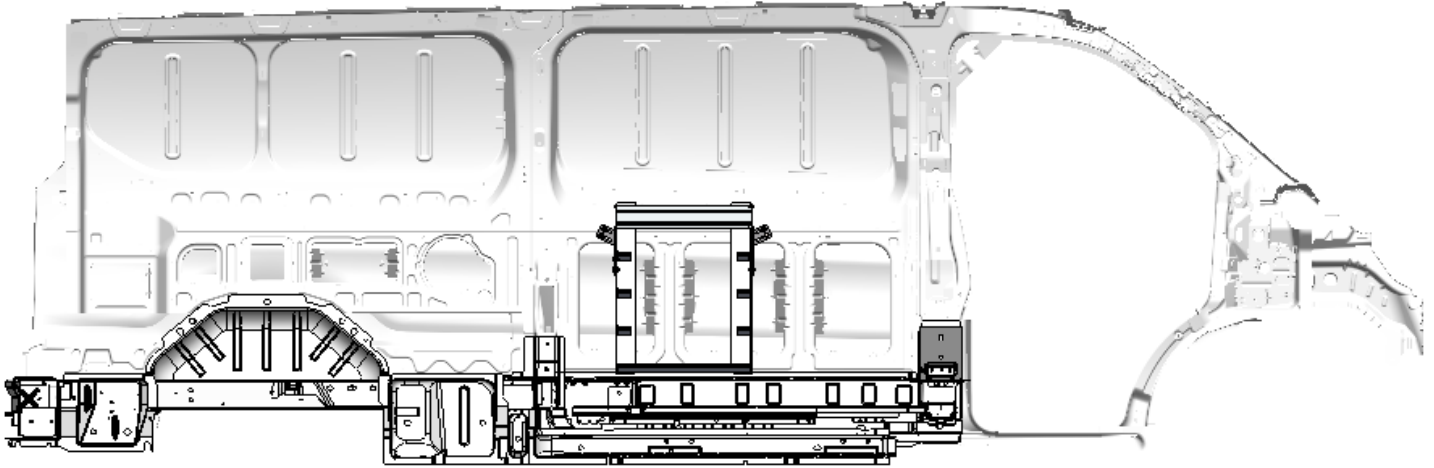

Fasten the Partskeeper Unit to the subfloor using square to position front 90° to the floor.

Tools Used:

Cordless Impact Driver
3/8" Nut Driver Bit
Large Square

Hardware Used:

4 x Hex Washer Head Screw #14 x 3/4"

Without Floor Kit

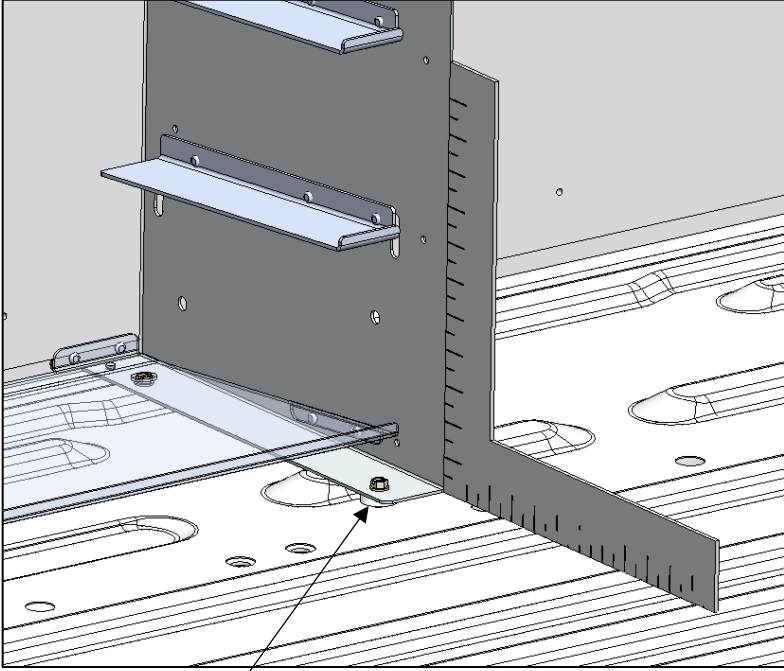
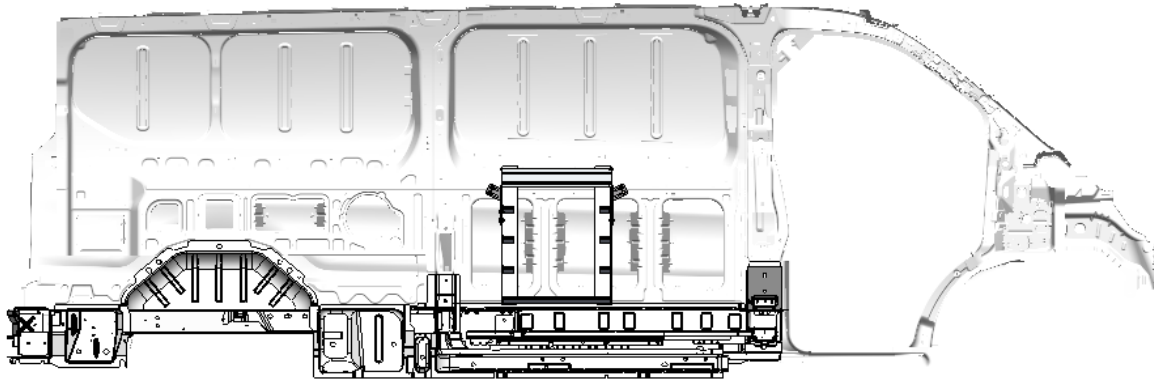

Fasten the Partskeeper Unit to the floor using square to position front 90° to the floor. Use 1/4 Nylon Spacers where necessary.

Tools Used:
Cordless Impact Driver
3/8" Nut Driver Bit
Large Square

Hardware Used:
4 x Hex Washer Head Screw #14 x 3/4"
1/4 Nylon Spacer

1/4 Nylon Spacer

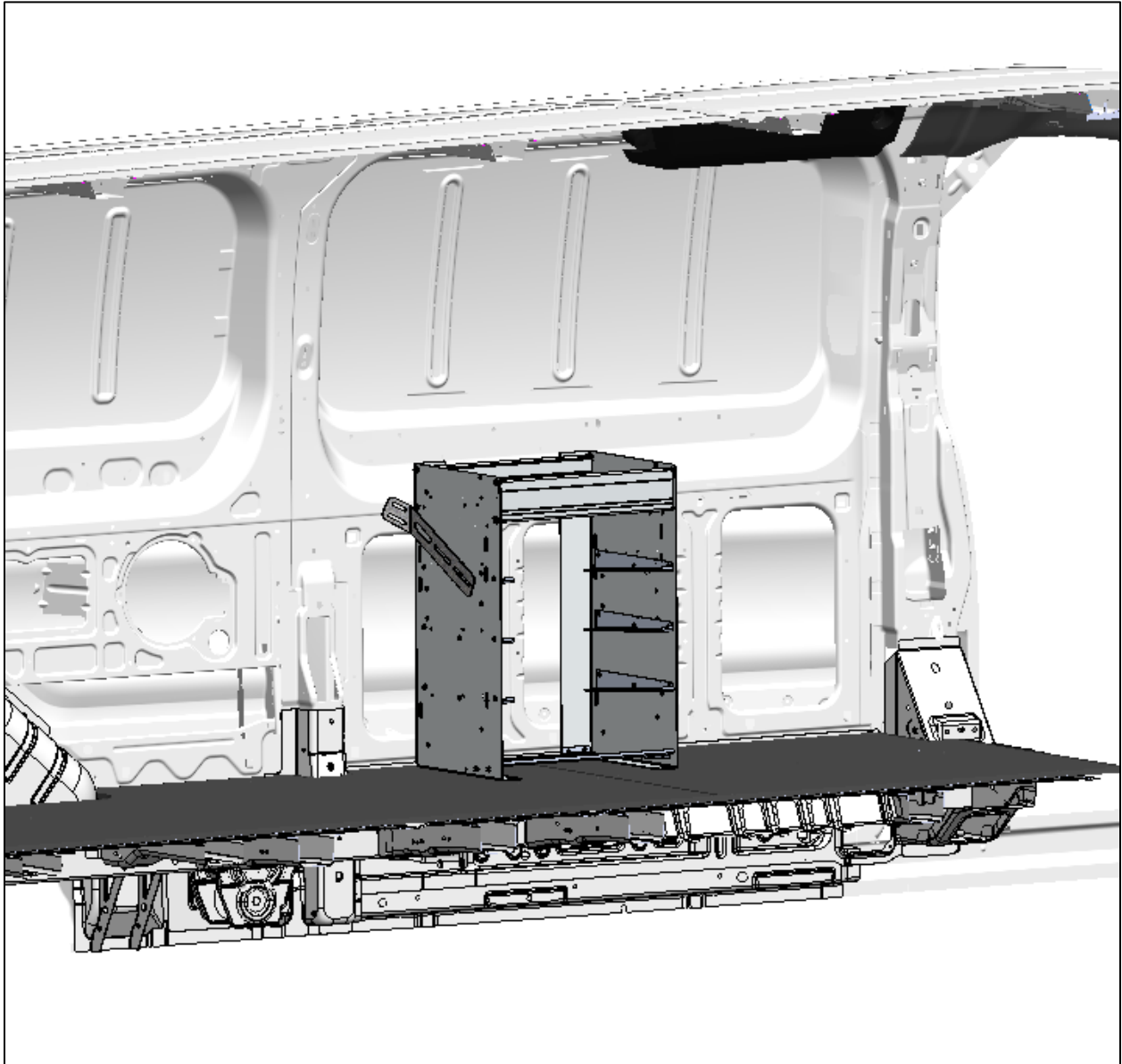

You have successfully installed your Parts Keeper Unit! If you have any questions or concerns, please contact us at (888)-796-3430